

Thread model



Chuck type



principle and characteristics

Compact diffused silicon pressure transmitter, wide choice, compact structure, suitable for harsh environment, high reliability. Wide range (0... 1000bar), which can be used to measure gauge pressure and absolute pressure. Suitable for mechanical equipment, hydraulic pneumatic device, locomotive, pressure control.

technical specification

- ◆ Measurement range: customized according to user requirements
 - ◆ Overload range: 1.5 times of measuring range
 - ◆ accuracy: 0.25%, 0.5%
 - ◆ linearity: $\pm 0.2\%$
 - ◆ Repeatability: $\leq \pm 0.1\%$
 - ◆ Stability: no more than the accuracy of the transmitter within 1 year
 - ◆ Temperature effect: $< \pm 0.02\%FS/K$
 - ◆ Response time: $< 1ms(10\% \dots 90\%FS)$
 - ◆ power supply: 10...30VDC(3-wire 14...30V)
 - ◆ load: $\geq 10K\Omega(0...10V), \geq 5K\Omega(1...5V)$
 $\leq (UB-10)V, 0.02A(4...20mA)$
 - ◆ Power consumption: Signal current (2-wire), 8mA(3-wire)
 - ◆ Electrical protection: overload/reverse phase protection
 - ◆ Ambient temperature: $-30\% \dots 85\text{ }^{\circ}C$
 - ◆ Medium temperature: $-25\% \dots 80\text{ }^{\circ}C$
 - ◆ Storage temperature: $-30\% \dots 100\text{ }^{\circ}C$
- Protection grade: IP65
- ◆ Shell material: 304 stainless steel
 - ◆ Liquid material: 304 stainless steel
 - ◆ Sealing: fluorine rubber
 - ◆ Weight: 0.10kg

dimension figure

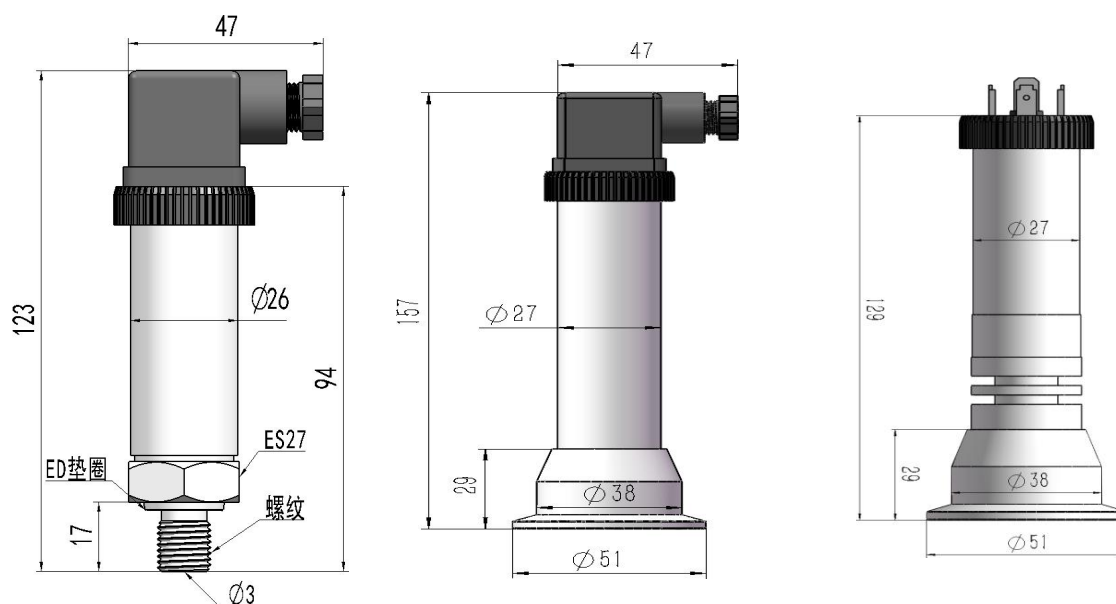

wiring diagram

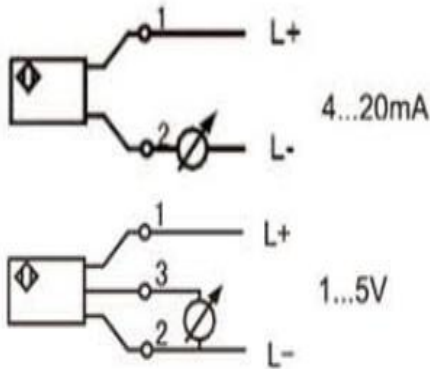

Range table

STANDAR	Gage pressure	Absolute
0--1bar	GB001	AB001
0--2bar	GB002	AB002
0--4bar	GB004	AB004
0--10bar	GB010	AB010
0--20bar	GB020	AB020
0--40bar	GB040	AB040
0--60bar	GB060	AB060
0--100bar	GB100	AB100
0--160bar	GB160	AB160
0--200bar	GB200	AB200
0--250bar	GB250	AB250
0--400bar	GB400	AB400
0--600bar	GB600	AB600

Selection table

PN500-	GB...	C	G4	H	4	B	B	specification
PN500-								PN500 series universal pressure transmitter
	GB...							Gauge range: bar (unit), refer to range table
	AB...							Absolute pressure range: bar (unit), refer to
	GP...							Optional range: kPa (unit), user defined
								Custom range
		B						Accuracy class: 0.25
		C						Accuracy grade: 0.5
			N4					Interface thread: NPT1/4
			N2					Interface thread: NPT1/2
			G4					Interface thread: G1/4
			G2					Interface thread: G1/2
			M2					Interface thread: M20*1.5
			P					Flush membrane connection
			K					Sanitary clamp connection
								Custom thread
				H				H: Female thread K: Female thread
					4			4-20 ma output
					1			1-5 v output
					0			0 to 10 v output
						B		B: Hersman connector
						A		A: Direct outgoing C: M12*1 connector
							B	No damper, no heat sink
							Z	Z: Damper S: Heat sink (optional)

* The selection table is only available for parameter selection, and the corresponding code is delivered.

Optional display header

F10-	A	specification
F10-		Display meter
	A	4-20 ma output
	B	1-5 v output
	C	0 to 10 v output

- * The display represents an electronic device used for digital display of a sensor signal, The desired display range can be set by setting button
- *Free programming through an unprocessed processor
- * No on-site setup required
- * With 4... 20mA output sensor
- *Protection class IP55

